

Instructions for Installing PLEXIGLAS® solid sheets

Planning

Careful planning and choosing the right tools, combined with correct storage and fabrication of PLEXIGLAS®, guarantees that you will be satisfied with the overall structure for a long time to come.



Tools/auxiliary agents

The following tools/auxiliary agents are required for installing PLEXIGLAS® solid sheets, depending on the type of project.

- Waterproof marker
- Medium to fine machine file
- Scraper
- Spray bottle
- Step drill
- Conical drill
- Countersink
- Metal drill with correct grinding for acrylic (point angle 60° to 90°)
- Contour cutter with stop ring
- Jigsaw blade with straight teeth and tooth pitch of 2.5 mm
- Circular saw blade with straight teeth (ideally trapezoidal flat teeth) and tooth pitch of approx. 13 mm



Storage

If PLEXIGLAS® solid sheets are not to be installed straight away, they should be stored correctly until used.

If possible, please store the sheets indoors. The PLEXIGLAS® solid sheets are protected against soiling and moisture during transport by PE sheeting. Please leave this sheeting in place if the sheets are stored outdoors.

The same applies to opened pallets.

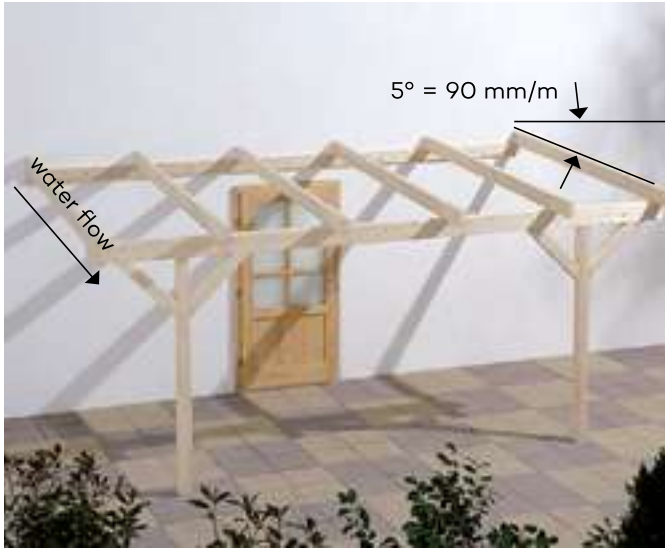

Roof pitch

Roofs glazed with PLEXIGLAS® solid sheets should have a roof pitch of at least 5° (= 90 mm/m) to allow rainwater to flow off safely. As a general rule, the greater the roof pitch, the better the roof can be cleaned by the rain.

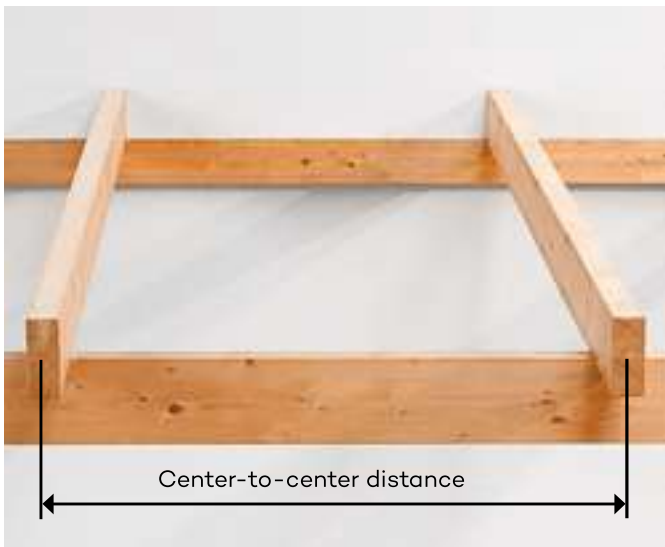

Center-to-center distance

The center-to-center distance (from the center of one support to the center of the next) provides sufficient allowance for widthwise expansion of PLEXIGLAS® solid sheets. It depends on the chosen glazing system and can be ascertained from PLEXIGLAS® suppliers. The center-to-center distance is calculated as the sheet width in mm + 6 mm for expansion + d of the fastening system. Given average snow loads and wind pressures of approx. 680 n/m², we recommend using a sheet thickness of at least 12 mm for a sheet width of approx. 1,000 mm. To reduce the amount of scrap, please bear in mind the standard sheet size of 3,050 x 2,030 mm.

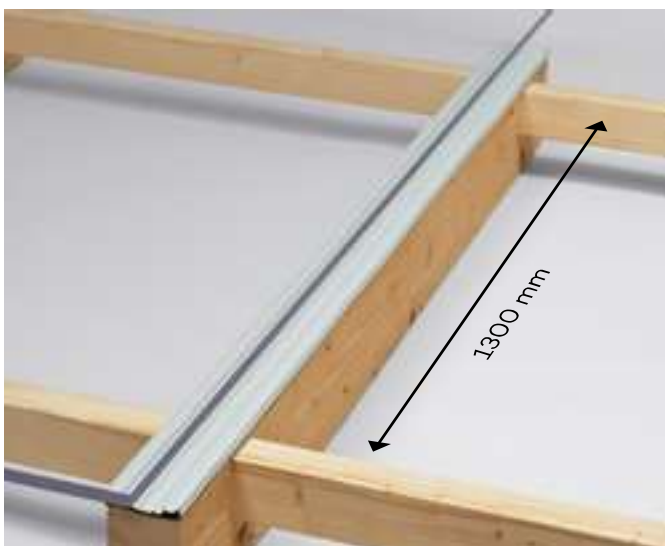

Crosswise supports

PLEXIGLAS® solid sheets with a thickness of 8 to 10 mm are installed on loadbearing supports on all four sides.

Given average snow loads and wind pressures of approx. 680 n/m², crosswise support spacing of approx. 1,300 mm is sufficient. The spacing must be reduced correspondingly for greater loads.



Material/Preventing heat buildup

The supporting structure should be non-warping and consist of laminated timber beams or metal. Dark surfaces heat up to a greater extent and faster than light-colored surfaces.

It is therefore very important to provide all structural surfaces facing the sheets with a durable white or reflective coating (e.g. light-resistant emulsion paint).

The coating on the supporting structure must be allowed to dry properly before installing the sheets.



Rebate depth

Owing to the linear expansion of the PLEXIGLAS® sheet, the rebate depth should be between 15 and 20 mm.



Expansion

An allowance "a" must be additionally made for sheet expansion. Value "a" depends on the sheet dimensions and corresponds to half of the overall allowance for expansion.

The allowance for expansion is 6 mm per meter.

Machining

The ease and almost unlimited variety of options with which PLEXIGLAS® can be machined are among its main advantages as compared with many other transparent materials. Using the correct tools is essential for successful work.



Cutting to size

High-speed circular (hand)saws with unset, multi-tooth carbide-tipped blades are most suitable for cutting PLEXIGLAS® solid sheets to size. The solid sheets should be secured against flutter. It is best to work with a stop, such as a wooden bar, to prevent the saw from tilting and causing an accident or damaging the cut edge of the sheet.



Corner cut-outs

If a corner needs to be cut out (e.g. to accommodate pipes, vents etc.), a hole should be drilled in the sheet at the point where the cuts intersect. To cut out corners, drill the hole first at the corner and then cut to it from the sheet edge, using a coarse-toothed jig saw without pendulum stroke. Marking is best done on the masking film, which should be left on the sheet while working on it and until it has been installed.



Drilling

If drill holes are required, e.g. for cutting out corners, use twist drills with special bits for acrylic (which “scrape rather than cut”), conical or step drills.

Installation

The pictures show typical glazing systems.

Whichever systems are chosen, take care to use only clamping bars, seals and other auxiliary agents and installation materials that are compatible with PLEXIGLAS®. This excludes plasticized

PVC, paint solvents, degreasing agents and other corrosive media.

In case of doubt, or to obtain information on the compatibility and function of different glazing systems, please contact your PLEXIGLAS® distributor.



Preference should always be given to linear fastening because this offers better load distribution and makes it possible to use thinner sheets.

PLEXIGLAS® is sensitive to certain sealing materials. Seals should therefore always be examined for their compatibility with PLEXIGLAS®.

The following are usually suitable:

- APTK (EPDM)
- Polychloroprene
- PE, PTFE, TPE and silicone rubber



Allowance for expansion

PLEXIGLAS® solid sheets expand due to heat and moisture. A general allowance is therefore to be made of approx. 6 mm/m of sheet length and width. The required gap between sheet and wall to make this allowance can be bridged for example by means of suitable wall connecting systems. An expansion clearance of 5 mm / m for a GS and XT sheet (6 mm / m for resist) must therefore be observed.





Length of the glazing bar

The glazing bar must be at least the same length as the purlin.

The leg length of the Aluminium Terminal Angle is usually added to the length of the purlin or glazing bar. This angle prevents the sheet from slipping.



Fastening the terminal angle

The Aluminium Terminal Angle is fastened by means of rivets or screws before installing the glazing bar.



Installing the glazing bars

The upper sections of the profiles should be fastened to the wooden or metal purlins by means of screws spaced approx. 330 mm apart.



Installing the glazing bars

Suitable PVC edge sections or special base edge sections or aluminium sections are used to close off the roof at the sides.

The upper sections of the glazing bars are fastened by means of suitable screws with washer.



optimized clamping system



excessive clamping pressure

Contact pressure

This pressure must be calculated in such a way that adequate tightness is achieved while the sheets can still slide in response to linear thermal expansion. If the contact pressure is too high, this may be detrimental to the system. Since the pressure mainly affects the weakest link in the fastening system, the elastic seal becomes excessively compressed.



Walking on the roof

It is often unavoidable to walk on the roof when installing the sheets and glazing bars.

Roofing with PLEXIGLAS® solid sheets should only be walked over by means of crawling boards that are at least 50 cm wide. These protect the sheet and comply with occupational safety standards. Placing a non-slip blanket or such between the PLEXIGLAS® sheet and the board protects the sheet from scratching.



Installing the glazing bars

Suitable screw-on wall connecting systems are available for roofs that touch the walls of the house. The sealing strips of these systems are incised at the points where they meet the glazing bars.



Installing the glazing bars

The wall connecting systems can be sealed at the wall using permanently flexible rubber. If butt joints and corners of glazing bars need to be sealed, e.g. using suitable silicone rubber, the latter must be compatible with PLEXIGLAS®. PLEXIGLAS® distributors offer suitable sealing compounds.



Removing the masking film

The masking film is removed when all the PLEXIGLAS® solid sheets have been installed.



Barrel vaults

On the supporting structure, the cut-to-size sheets are cold-curved over correspondingly formed (metal) hoops and fastened with glazing bars (e.g. screwed down between the sheets) over the arc length. The same system is used to fasten the lower ends to the longitudinal gutter sections. Compatible seals are used in between the clamping system and the sheet.

Cold curving generates stress within the material that has to be limited. Therefore it is essential to observe the minimum cold-bending radius specified for a given sheet material and thickness.

Minimum cold-bending radius

Minimum cold-bending radius in mm per thickness in mm							
	Equation	3	4	5	6	8	10
PLEXIGLAS® GS und XT	$r_{\min} = 330 \times \text{thickness}$	990	1320	1650	1980	2640	3300
PLEXIGLAS® Resist 65	$r_{\min} = 250 \times \text{thickness}$	750	1000	1250	1500	2000	2500

Sheet thickness for barrel vaults

The required sheet thickness can be taken from the graphic below. The values were calculated with a safety factor of 1.5 against buckling, according to E.R. Berger: "An approximation formula for the buckling stress on a concentrically compressed arched

shell", Beton- und Stahlbau 48 (1953), page 288. These data are meant as a guideline for our customers. Where proof is required, people carrying out projects should entrust a static engineer with the calculations.

Sheet thickness in mm for barrel vaults with a hoop spacing of 1,000 mm and a wind pressure/snow load (radial pressure) of 750 N/m²

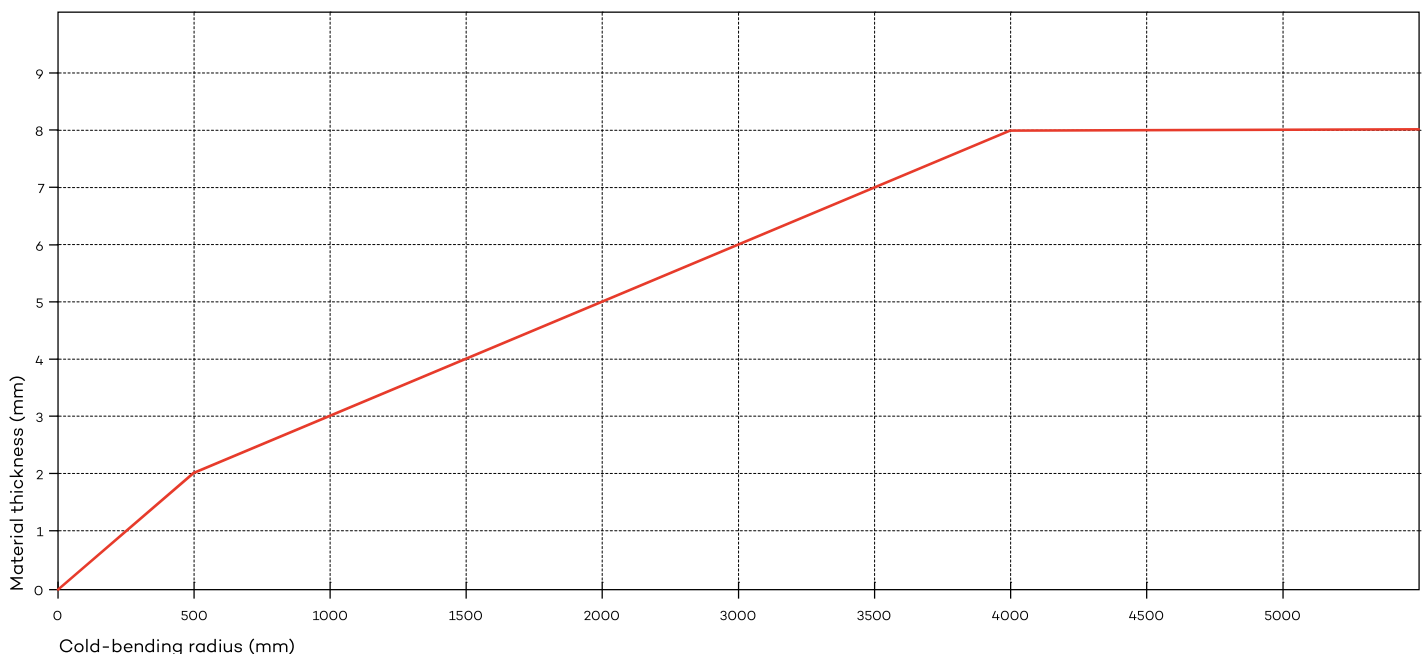

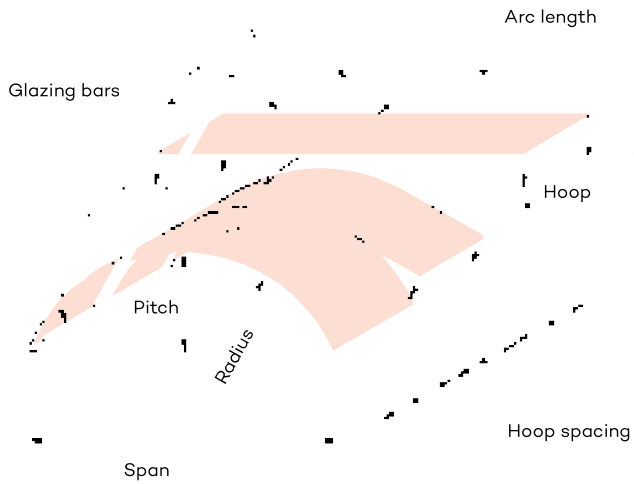

Optimal hoop spacing

We recommend a hoop spacing of approx. 1,000 mm. To produce as little scrap as possible, please bear in mind the standard sheet size of 3,050 x 2,030 mm.

In the case of barrel vaults with greater arc lengths than the available sheet lengths, the arc has to be divided up (at the ridge or several times) by putting several cut-to-size sheets together with transverse joints. The same clamping systems as for the curved hoops are to be used for the transverse joints and due allowance is to be made for sheet expansion.



Canopy systems

If a pointwise fastening technique is used, it must be appropriate for the chosen material. This variant looks particularly elegant if the sheet edges are polished. The drill hole in the sheet must be much larger than the screw thread. Protect the sheet wall inside the drill hole with a compatible sleeve (e.g. polyethylene) around the thread. Use large washers (at least 60 mm in diameter) with the screws and compatible elastic seals (e.g. EPDM rubber).

Tighten the screws only to such an extent that the sheets are still able to move.

- The maximum projection of the canopy should be 1,200 mm.
- The spacing between drill hole and sheet edge should be approx. 150 mm.
- Fastening points should be spaced at about 330 mm.
- The roof pitch should be at least 5–10° (= 90–180 mm/m).
- Sheet thickness from 12 mm

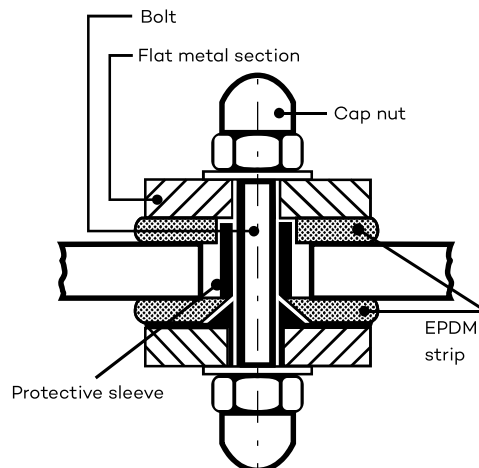

Cleaning

A roof glazed with PLEXIGLAS® solid sheets offers its owner unalloyed pleasure. To make sure it stays that way, it is important to know a few things about the material's properties.

Always make sure to use only cleaning agents that are compatible with PLEXIGLAS® (i.e. no strong industrial cleaning agents, insecticides, solvents or other corrosive agents).



Cleaning

There is no need to clean the outside of the sheet, given adequate roof pitch and vertical glazing. The rain will wash off any soiling. Should cleaning be necessary, use a garden hose or clear, warm water with a little added household dishwashing liquid. Do not use abrasive cleaning agents. Only use cleaning and auxiliary agents that are compatible with PLEXIGLAS®.

Suitable cleaning agents are

- lukewarm water with a little added dishwashing liquid
- concentrated vinegar diluted with water
- isopropyl alcohol (2-propanol)
- pure naphtha
- a soft, damp viscose sponge
- a soft, damp, non-linting cloth
- a sponge cloth
- chamois leather
- glove-lining fabric
- cotton dishcloth
- shower cabin squeegee with soft rubber blade
- damp microfiber polishing cloth (e.g. Vileda® Microclean)